



HYDRA[®]

INSTALL



HYDRA

ECHO PRO

AC Wall Mounted EV charger

**ELECTRIC VEHICLE CHARGER
INSTALLATION AND INSTRUCTION MANUAL**

CONTENTS



HYDRA®

INSTALL

SAFETY	3
Safety Identification	3
INTRODUCTION	7
Appearance	7
Technical Specifications.....	8
Manual Information	9
Terminology.....	10
Product model	10
Lighting Language.....	10
INSTALLATION	11
Procedure.....	11
Accessory List.....	11
Site preparation.....	12
Unpacking The Charger	12
Mounting The Plate	13
Mounting The Charger	14
Wiring.....	15
Daisy Chain	16
Connecting Ethernet.....	17
SIM CARD	18
Sim Card Installation	18
COMMISSIONING	19
Commissioning Checklist.....	19
Setting Up The Charger.....	20
Configuration Settings	20
PROTECTION	21
Protection Device	21
CHARGING OPERATION	22
Charging Procedure	22
Service	24
Troubleshooting	24
Service.....	24
AFTERSALES	25
Aftersales Service	25
Disclaimer	25
Maintenance.....	25



OPERATORS AND INSTALLERS RESPONSIBILITY

Hydra EVC AC charger Installation Instructions and Installation Guides are intended for operators who are responsible for installing, operating, servicing and maintaining an AC charge point. Installers should thoroughly understand electrical systems and electric vehicle charging infrastructure. Before performing any task, operators and responsible technical personnel should read these instructions carefully. The installer is the qualified person who installs the charger on-site. The installer should:

- Hold relevant qualifications to complete the installation according to local regulations and standards.
- Hold relevant qualifications to work with commercial electrical installations and be able to certify installation according to local regulations.
- Follow local health and safety rules and wear the right PPE to minimize exposure to hazards.
- Complete Hydra EVC training for Installers and become a certified Hydra EVC AC charger Approved Installer.
- Make sure installation is complete according to the “Hydra Installation Manual”.
- Install an Upstream Protection Device according to Local Regulations and Earthing System.
- Complete the Site Survey before installation to calculate the Supply Cable Size, according to cable type, installation reference method, upstream over-current protection device size, AC Charger output power and circuit length.

SAFETY INSTRUCTIONS

The Hydra EVC AC charge point can only be installed and maintained during a power shutdown. Before any installation, dismantling, repair or exchange of components, the supply protection device and internal group switches of the Hydra EVC AC cabinet must be switched off. A Safe Isolation Procedure must be carried out to ensure that electrical power is disconnected from the system. Only certified EVSE installers are authorized to install, disassemble, repair, or replace parts on an Hydra EVC AC charge point. After installation, service, or repair, the charger cabinet must be securely closed and locked.

According to local electrical regulations, the Hydra EVC AC charger must be connected to a Protective Earth ground conductor. Before connecting the input power supply, ensure that the grounding is reliable.

CYBER SECURITY

It is the responsibility of the Owner to ensure that the product is securely connected and communicates with a network interface. The Owner must take the necessary steps to protect the AC charger, network, system, and interface from any security breaches, unauthorized access, interfering, intrusion, leakage, or theft of data or information. Hydra EVC shall not be liable for any damages or losses incurred as a result of security breaches.

DISPOSAL INSTRUCTIONS

To prevent adverse environmental and human health impacts caused by potentially hazardous substances, parts should be disposed of in accordance with local regulations and guidelines.

INTRODUCTION



HYDRA[®]

INSTALL

APPEARANCE

Use	Car Parks / Public Charging Station
Material	Metal housing
Installation type	Wall Mounted
Cable layout	Bottom
Weight	18kg
Charging socket	Type 2

- 1 Touch Screen
- 2 RFID Card reader
- 3 LED status lights
- 4 Power input
- 5 Charger Socket



INTRODUCTION



HYDRA[®]

INSTALL

TECHNICAL SPECIFICATIONS

General	Dimensions (mm)	L500 x W240 x D199 (mm)
	Weight	18kg
	Operating Temperature	-25°C to +50°C
	Storage Temperature	-40°C to +80°C
	Material	ABS Plastic and aluminium alloy
	Certifications	CE/UKCA
	Charing Power	7.4/22kW
Charging	Charging Current	6-32A (adjustable) per phase
	Voltage	230/400V (1/3-phase, 50-60Hz)
	Charging Mode	Mode 3
	Charging Socket	Type 2
	Fixed Charging Cable	No
Interface	Energy Metering	Integrated MID meter ($\pm 1\%$) accuracy on readings
	User App Configuration	Control charging with the commerical app
	Charging Status	Dynamic LED ring for charging status
	Authentication	App controlled/Plug & Charge/Built-in RFID/NFC reader
	Cloud Connection/Network	4G LTE, LAN
	Communications Protocol	OCPP 1.6J, OCPP 2.0.1 (future)
Installation	Installer App and Configuration	Configure with the installer app through Bluetooth Low Energy (BLE 4.2)
	Installation Circuit	40A Circuit Breaker
	Cable Diameter	Max. 25mm
Saftey and Protection	RCBO	30mA AC + 6mA DC
	Overvoltage Category	III
	Instulation Class	I
	Fire Classification	UL94
	IP Rating	IP54
	Impact Resistance	IK10
	Temperature Monitoring	Internal sensors
	O-PEN Detection	Integrated

INTRODUCTION



HYDRA[®]

— INSTALL —

MANUAL INFORMATION

About this Manual

This manual describes the installation, operations and safety maintenance of the Hydra EVC AC charger. Before installation, please read this manual to ensure a successful installation, operation and safety maintenance.

Target Group

This document is intended for professional or other qualified personnel only. Qualified personnel must possess the following skills:

- Knowledge of how the product operates and how to use it.
- Knowledge of commercial electrical installation and ability to test and certify installation.
- Understand how to address hazards and risks related to the installation and use of electrical equipment.
- Understand equipment installation and commissioning.
- Understand all relevant standards and directives.
- Understand and follow the instructions in this manual, as well as all safety information.

Compliance

If you are considering installing the Hydra EVC AC charging station, it is important to read this manual carefully and talk to a licensed contractor, electrician, or trained installation expert. They will be able to help you make sure you meet all local and national codes and safety standards, as well as any applicable laws. The most common installation and mounting scenarios are outlined in this document.

Disclaimer of Warranties

This document is copyrighted and can only be used with permission from Hydra EVC. This manual is based on the most up-to-date information available when it is printed. It is subject to any changes that Hydra EVC may make without prior notice. Although the accuracy of the information in this manual has been verified, there is no assurance that it is complete and accurate. This includes, but is not limited to, product specifications, functionalities, and illustrations. Hydra EVC is not responsible for any losses or damages that may arise from using this document, including but not limited to lost profit or data. If you use or modify the Hydra EVC AC charging station in a way that is not intended to be used or modify the charge point, your limited warranty will be void.

Illustrations

This document cannot display all the configurations of AC charge point. Therefore, the illustrations in this document only shows the typical settings. They are only used for instruction and descriptions about installation.

Language

The original description of this document is written in English. All other language versions are translated versions of this document.

INTRODUCTION



HYDRA[®]

INSTALL

TERMINOLOGY

Abbreviations	Definition
AC	Alternating Current
EV	Electric Vehicle
OCPP	Open Charge Point Protocol
PE	Protective Earth
RCBO	Residual Current Breaker with Over Current Device
RFID	Radio-frequency Identification

PRODUCT MODEL

Part Code	Version
HE-P-22-S0	Hydra Echo Pro 22kw Socket Only

LIGHTNING LANGUAGE

LED Ring Status	Description
Power LED Charger Free	Ring Light Green On
Reservation	Ring Light Blue On
Connected	Ring Light Green Flash
Charging	Ring Light Green Breathing
Charging Finished	Ring Light Yellow Flash
Charging Error	Ring Light Red On
PEN Error	Ring Light Red Flash

INSTALLATION



HYDRA[®]

— **INSTALL** —

PROCEDURE

SAFETY INSTRUCTIONS

The operating voltage and current inside the charging system are high, and the following regulations should be observed at all times to ensure personal safety:

1. Charging systems must only be installed by personnel who have been trained in, and have sufficient knowledge of, the charging system. Always follow safety precautions and local safety regulations during installation.
2. To operate inside the charging system, make sure that the charging system is not live. The power input to the charging system must be disconnected.
3. Distribution cable wiring should be reasonable and protective to avoid accidental contact when operating power supplies.

VISUAL INSPECTION

Upon product delivery, check that the package is not damaged and that the label is complete and correct. If there is an issue, immediately inform the carrier and take photos as evidence. At the same time, immediately contact the manufacturer to discuss the issue.

Only after the goods arrive at the installation site can they be opened and the boxes opened for inspection. Start by opening the box with the packing slip, taking out the packing list and checking it against each item. Next, check the serial number of the box, the equipment packaging, the number and type of accessories and the integrity of all items.

Following the packing list, check that accessories and accompanying documents are complete (refer to the shipping list) and store the accessories and documents properly.

Carry out a visual inspection to ensure that the product is free of abnormal marks showing collisions, and of scratches, cracks, dents, rust, breakage, or peeling of paint.

Sign receipt documents, make a record of the situation, keep documents and scan them for archives, or give them to relevant parties.

ACCESSORY LIST



Charging Station



Screw (M5 x 60)
4 PCS



Tools (110*20*25)



Install Plate

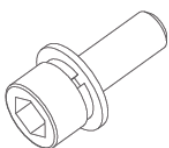

Screw (M5 x 14)
2 PCS

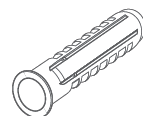

Screw (M8 x 60)
4 PCS

INSTALLATION



HYDRA[®]
— **INSTALL** —

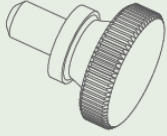

Install Screw



Net Cable
Protective Ring



Input Protective Ring

SITE PREPARATION

Before installation, all local legal requirements applicable to the installation site must be met. Before installation of the Hydra Genesis AC public charger, ensure that:

- Concentrate foundation base is prepared according to the manual.
- Space and the airflow around the cabinet is sufficient.
- Installation site design complies with local requirements and regulations.
- Cable duct is sufficient to guide supply cables to the cabinet.
- Installation is protected with a capable rating upstream protection device.
- The charger supply circuit is protected by an upstream RCD device if the installation method or local regulation requires upstream RCD protection.
- Site survey and cable calculation are completed to select the right CSA of charge point supply circuit cable.
- A transport company delivers the charger close to the site. The movement of the charger to its final location is your responsibility.
- If you need to store the charger before installation, obey the ambient conditions for storage.

UNPACKING THE CHARGER

- Remove the charger from the package.
- Remove all the packaging material from the charger.
- Make sure that all the parts are delivered according to the order.
- Checking the charger and the parts. If you find damage or the parts are not consistent with the order, contact your local dealer.

INSTALLATION



HYDRA[®]

INSTALL

MOUNTING THE PLATE

1. Make sure that the installation is level on the wall, and recommended height is about 800-1200 mm.
2. Drill the mounting holes.
3. Charger back module install-fix on the panel.

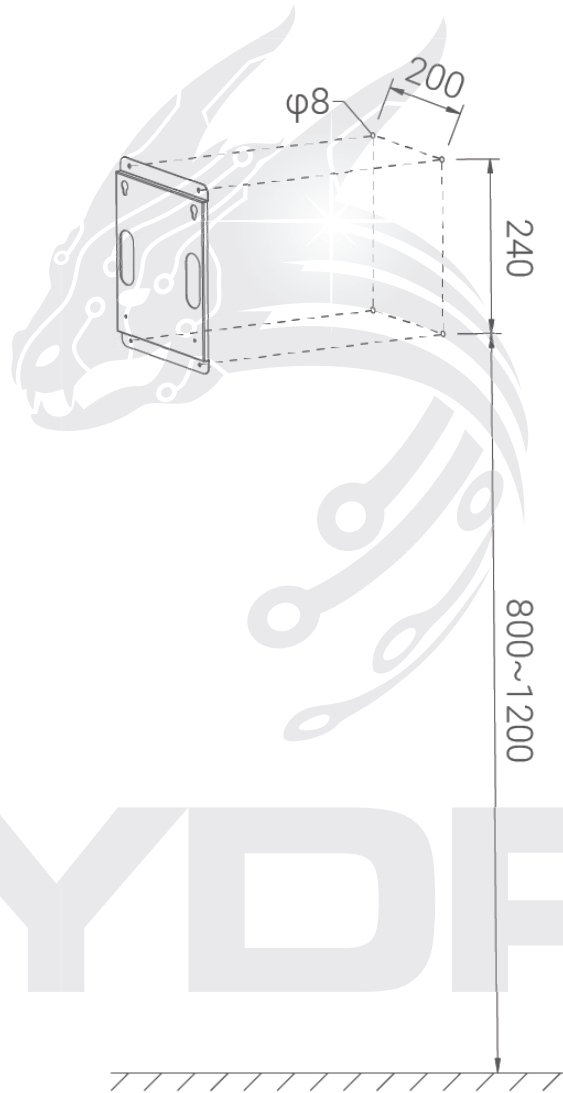

Screw M5*60 x 4
4 PCS

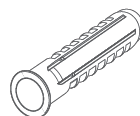

Screw M8*60 x 4
4 PCS



MOUNTING THE CHARGER

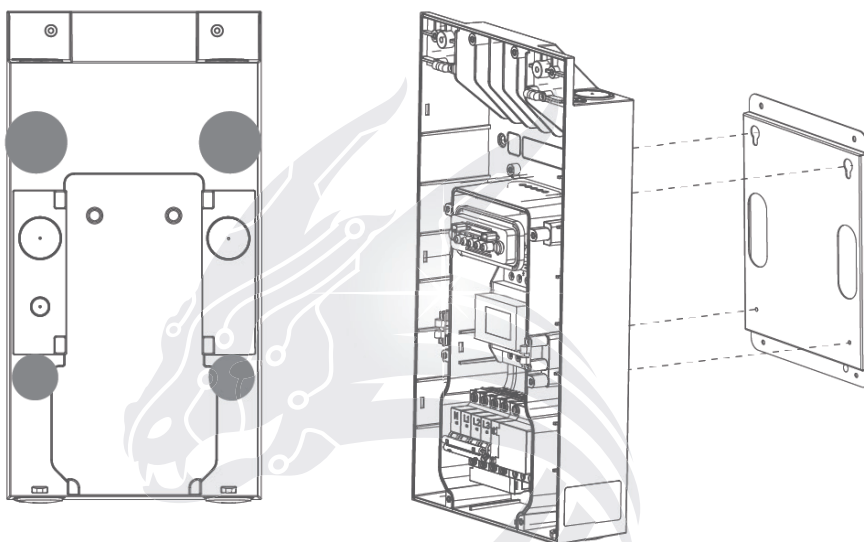

1. Confirm the power input location, and back module support top and bottom input.
2. Fix the charging module with back module after finish the power connection.

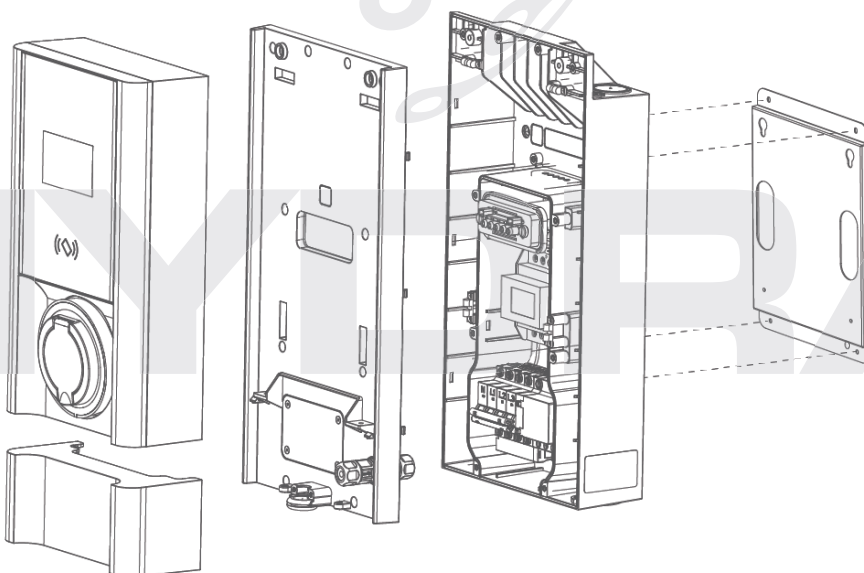

- We recommend the height for wallbox is about 800-1200mm
- Install the charger on a flat and vertical surface capable of supporting its weight



WIRING

Connect the AC input wires

1. Trim the wires L1, L2, L3, PE and N. And make sure that the length is sufficient for connection at the connectors
2. Strip the insulation from the end of the wires. Make sure that the strip length is compatible with the cable lugs
3. Attach the cable lugs to the end of the wires. Use the cable lug tool
4. Tie the wires N, L1, L2, PE and L3 to the AC input conductor terminal
5. Torque requirements is 3-4 Nm

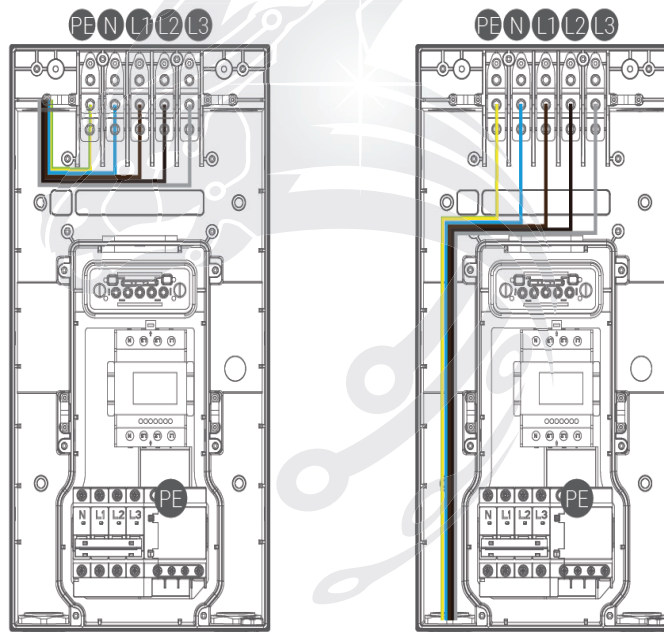

Top Input Connection

Bottom Input Connection

Make sure the upstream RCBO or MCCB off, keep the RCBO off of charger, then connect the wiring to charger's terminal.



DAISY CHAIN

There are two ways for input cable of wallbox charger (Top or Bottom), make sure that use the bottom way if the wallbox installed outdoor. (This is limited to two units only)

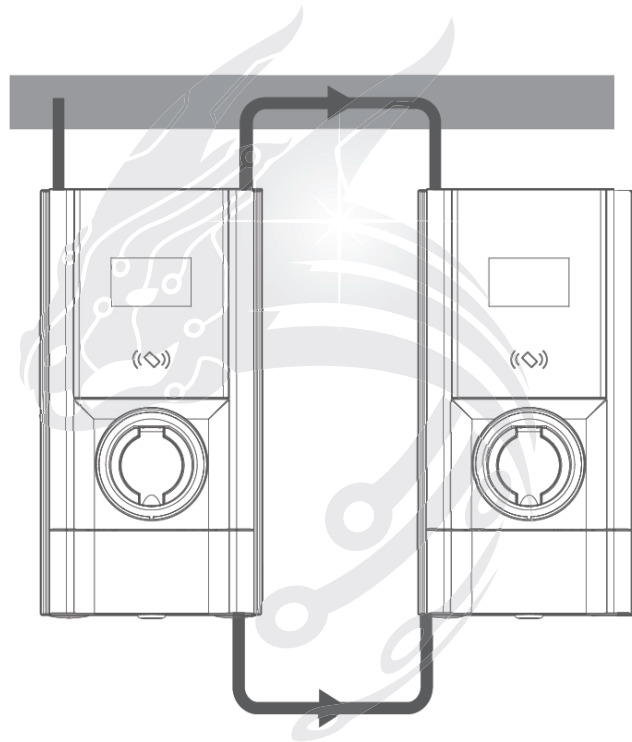

HYDRA



CONNECTING ETHERNET

The charger can be connected to the Internet by Ethernet connection, Wi-Fi or a SIM card.

1. To connect via the Ethernet cable, put the RJ45 plug of the Ethernet cable into the RJ45 port (H) in the back module of charger.

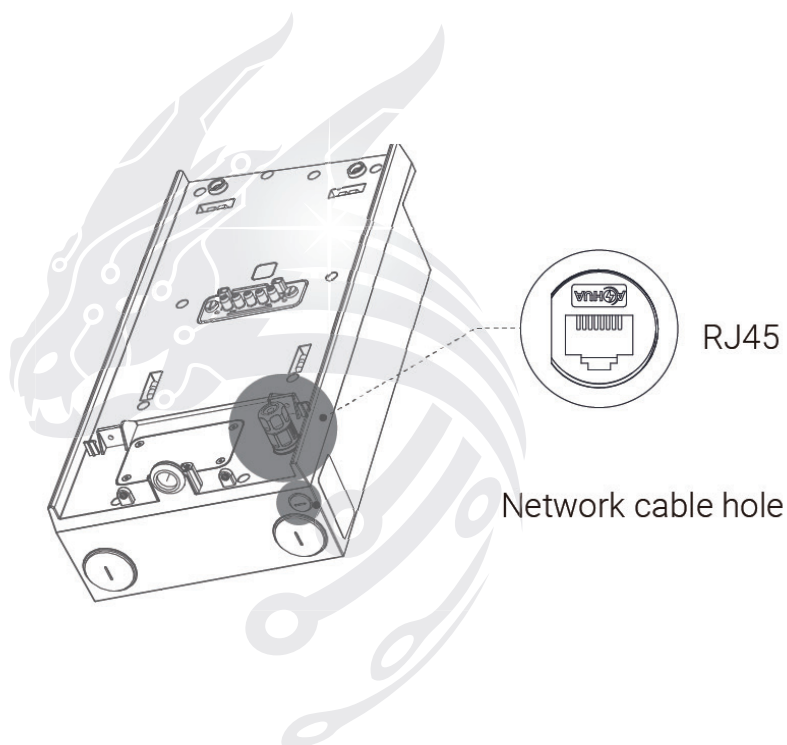

HYDRA

SIM CARD



HYDRA[®]
— **INSTALL** —

SIM CARD INSTALLATION

When planning the SIM card connection for charger at a site, there are a few key considerations to keep in mind. It is important to choose a reliable and robust network provider that offers good coverage in the area where the charger will be installed. This ensures a stable and consistent network connection for the charger. Considering factors such as the expected usage, number of charging sessions, and the amount of data that will be transmitted, ensures there will be sufficient data allowance for smooth operation. Carefully consider these factors when planning for SIM card connection for AC charger at a public site, ensures you can provide a reliable and efficient charging service for electric vehicle users.

To install a SIM, follow the next steps:

- A. Ensure that the charger is powered off before proceeding with the installation.
- B. The SIM card slot is located on the bottom side of the charging module. Remove the cover of wallbox or open the door of pedestal version to get access to the SIM card slots.
- C. Take the SIM card out of its packaging and handle it carefully to avoid any damage. Identify the correct orientation of the SIM card. Most SIM cards have a small notch in one corner. Align this notch with the corresponding notch or diagram on the SIM card slot.
- D. Gently insert the SIM card into the slot, making sure it is properly seated. Be careful not to force it in or insert it upside down. Once the SIM card is inserted, push it in until it clicks into place or until it is securely held by the SIM card slot.
- E. After the SIM card is installed, install the back protection cover of wallbox or close the front doors for pedestal version, making sure you don't leave any tools inside the cabinet and the doors are locked.

HYDRA



COMMISSIONING

Commissioning is the necessary before the charger operation. The purpose is to check the safety and performance of the charging system for operational purposes. A qualified service engineer from Hydra EVC service or a qualified engineer is required to go to the site for commissioning. During commissioning, the system safety performance and the function of charging will be tested. Before the service engineer commissioning, the owner needs to prepare and confirm the following conditions as below.

1. All the preparation: foundation, installation and connection are ready for the charger.
2. Assign local project technicians to provide on-site assistance and power operation.
3. Network cable connection should be ready with 3G/4G.
4. To prepare a EV or PHEV car for the charging test.
5. Assign a technician to on-site have a training.

COMMISSIONING CHECKLIST

S/N	Checking Items	Checking Result		Remark
1	Ensure that the charger is securely fixed	<input type="checkbox"/> Pass	<input type="checkbox"/> Fail	
2	Check the charger is well ventilated and door open freely	<input type="checkbox"/> Pass	<input type="checkbox"/> Fail	
3	Check the inside and outside surface of the charger whether be damage	<input type="checkbox"/> Pass	<input type="checkbox"/> Fail	
4	Check each charger connector is fine	<input type="checkbox"/> Pass	<input type="checkbox"/> Fail	
5	Check that the internal control board and related connection are well secured	<input type="checkbox"/> Pass	<input type="checkbox"/> Fail	
6	Check that the ground wire is well connected	<input type="checkbox"/> Pass	<input type="checkbox"/> Fail	
7	Use multi-meter test the upstream RCBO, and confirm the voltage (400V±10%, 230V±10%) PE-L1 = V PE-L2 = V PE-L3 = V N - L1 = V N - L2 = V N - L3 = V L1-L2 = V L1-L3 = V L2-L3 = V	<input type="checkbox"/> Pass	<input type="checkbox"/> Fail	
8	Power On the upstream RCBO and check the voltage, and confirm the voltage in charger site (400V±10%, 230V±10%) PE-L1 = V PE-L2 = V PE-L3 = V N - L1 = V N - L2 = V N - L3 = V L1-L2 = V L1-L3 = V L2-L3 = V	<input type="checkbox"/> Pass	<input type="checkbox"/> Fail	
9	Power On for charger	<input type="checkbox"/> Pass	<input type="checkbox"/> Fail	
10	The screen will display	<input type="checkbox"/> Pass	<input type="checkbox"/> Fail	
11	Check the safety sensor function for tamper(Wallbox)	<input type="checkbox"/> Pass	<input type="checkbox"/> Fail	
12	Check the safety sensor for door of pedestal	<input type="checkbox"/> Pass	<input type="checkbox"/> Fail	

- Make sure the commissioning engineer is qualified
- Make sure all the checking list all pass, then do the next step, and sign with customer about commissioning document.



SETTING UP THE CHARGER

Be careful when you work with electricity

The power supply comes on and test all the input voltage with multi-meter tool.
A series of self-checks start, to make sure that the charger works correctly and safely.

1. Download the EVbee service app.
2. Before powering up the charger, close the breaker that supplies the power to the charger.
3. Open the EVbee service app connect with charger.
4. Do step by step , on the EVbee service app.
 - a. Update the product firmware, if necessary.
 - b. Adjust the parameter settings for your charger.
 - c. Select the platform for charger connection, if not pre-set.

Reinstall all the cover and checking

1. Make sure turn off the charger, then reinstall the inner cover by tightening the five screws to the right torque.
2. Check if there are screws or tools inside the pedestal, then turn on again

CONFIGURATION SETTINGS

Setting the Parameter

In 'Home' page, select upper-right and input password when you configured the charger, this will go to charger configuration settings page.

Settings

- a. Select 'Network & Backend' will go to the network connection settings.
- b. Select 'Charging parameter' will go to charger limitation settings.
- c. Select 'Energy Management' will go to LDB parameters setting.
- d. Select 'System' will display hardware and software information.
- e. Select 'Home' will return to the home page.

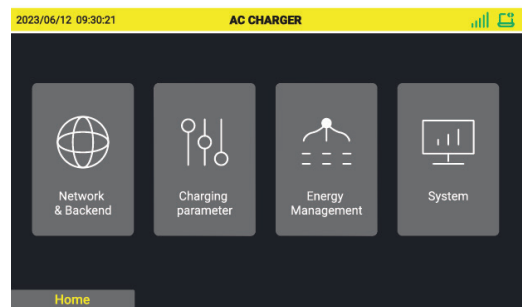
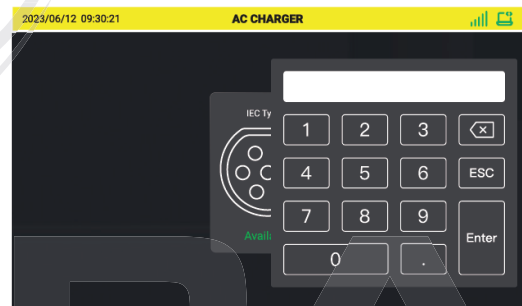

PROTECTION



HYDRA[®]

INSTALL

PROTECTIVE DEVICE

Devices

Specifications

Dedicated upstream protection device(s)

Options:
RCD (Type A minimum) + MCB RCBO (Type A minimum)

Upstream overcurrent protection breaker, such as RCBO or MCB (The breaker serves as the main disconnect switch to the charger.)

Breaker rating:
40 A for a wallbox & Pedestal single charger 80 A for Pedestal Dual charger

Upstream residual-current device (RCD)

Minimum Type A, with a rated residual operation current of maximum 30 mA (Internal to charger is DC fault current monitoring > 6 mA.)

In some countries, local standards may require external protection devices. Check your local standards accordingly. External RCD+MCB or RCBO are also recommended as below:

Devices

Specifications

22kW

30 mA Type A RCBO 400 V/40 A

Otherwise, comply with local regulations.

For daisy chain connection, please consider the total power rate and select the main RCBO or MCB, all of the installation must comply with local regulations.

HYDRA

CHARGING OPERATION



HYDRA[®]

INSTALL

CHARGING PROCEDURE

System Start Up

Power on the charger, the charger will start initializing and display power on page.



After initializing, when charger is standby, will stay on 'Home' page

- Plug in car
- Select operations from options on the screen

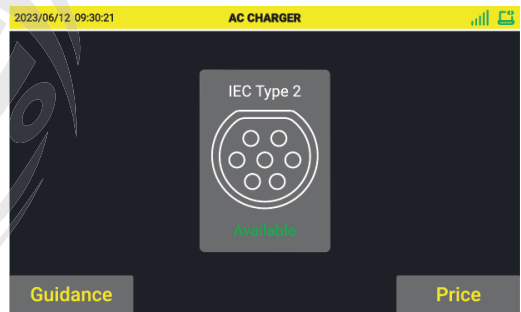

Authorize to start a charging session

- Use APP to scan QR code to start charging.
 - Select 'Credit Card' and swipe credit/Debit card on contactless device to start charging.
 - Select 'RFID Card' and swipe RFID card on charger to start charging.
- Select 'Home' will return to the Home page.

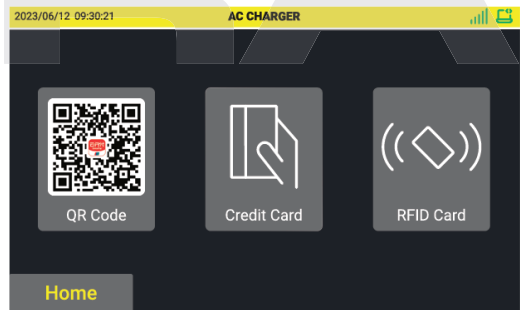

CHARGING OPERATION



HYDRA[®]

INSTALL

CHARGING PROCEDURE

Charging page

- Select 'stop' button, will go to authorization page to stop.
- Select 'Price' will display unit price per kWh or per minute.
- Select 'Home' button will return to the home page.
- Select 'details' button will display more charging info.

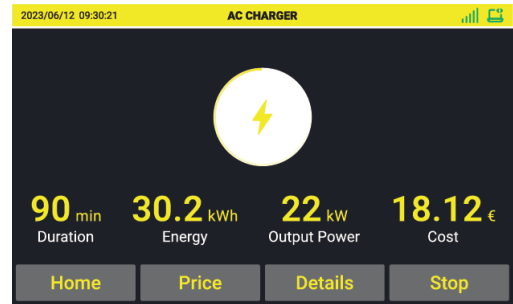

Authorize to stop the charging session

However you started the session whether this be and RFID card, credit/debit card or QR code you **MUST** use this to end the session too.

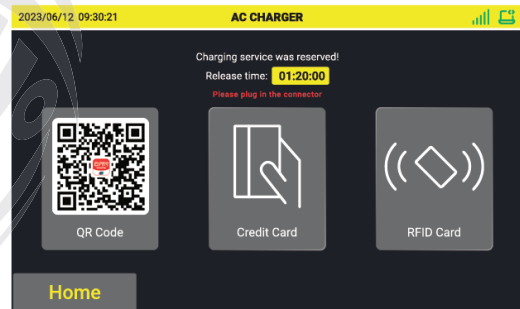

Stop charging page

- Select 'Home' button will return to the home page.
- Pull out the connector will return to the home page.

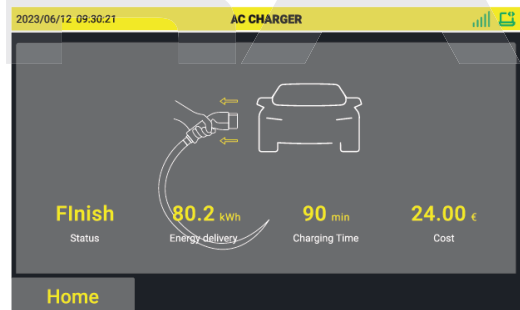



TROUBLESHOOTING

Item	Problem	Solutions
1	Bluetooth connection fails	Make sure Service APP is enabled on your mobile device.
2	Over-voltage	Use the multi-meter to check whether the voltage on the power input is too high. If the result is greater than voltage (253 V), contact local power grid company.
3	Under-voltage	Use the multi-meter to check whether the voltage on the power input is not sufficient. If the result is less than voltage (207 V), contact local power grid company.
4	Ground fault	Make sure the charger is earthed correctly.
5	Residual current detected	Unplug the vehicle and plug in again. If the problem persists, contact your local representative.
6	Over current	Restart charger and unplug the vehicle and plug it again.

SERVICE

In product life cycle, if you cannot find solutions to your problems about software, hardware or others with the aid from the table above, please contact Hydra EVC Technical Support.

Hydra EVC Ltd
Email: support@hydraev.co.uk
Address: Unit 11 Totman Close, Rayleigh, Essex, SS6 7UZ

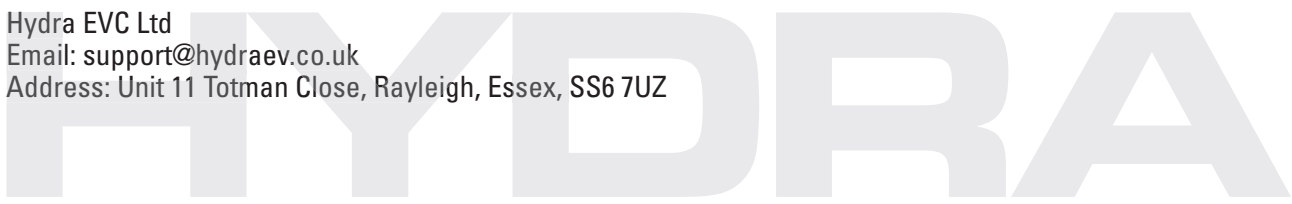

AFTER-SALES MAINTENANCE



HYDRA[®]
— **INSTALL** —

AFTER-SALES SERVICE

- Parts are covered by a three-year warranty.
- During this period any defective part will be replaced.
- One-to-one technical engineer support is available.

DISCLAIMER

Product equipment must be used under certain conditions. Should the following circumstances lead to an accident or damage, we will not be held responsible.

Opening the door must be carried out in standby mode and, if necessary, the power input needs to be disconnected.

- All human factors, damage and use in an abnormal working environment
- Failures and damage caused by improperly using the device or not following instructions.
- Damage caused by transport after delivery.
- Normal wear, breach or immersion.
- Use of parts not authorised by the manufacturer (such as aftermarket or counterfeit parts).
- Dismantling, repairing or modifying the products without the prior consent of the company.
- Damage caused by flood, fire, lightning strike, typhoons, earthquakes or abnormal voltage.
- Accidents, faults or damages outside the warranty period.

MAINTENANCE

DAILY MAINTENANCE

Regular servicing maintains the charger's safety and condition.

REGULAR MAINTENANCE

MONTHLY

- Check the charger is still perfectly upright.
- Clean any dirt on the outer surface.
- Check for damage to the painted surface.
- Test the charging outlets and cables.
- Check the LED display status.

QUARTERLY

- Check the ground screw and ground resistance (no greater than 1Ω).
- Check the charger's alarm light is green and the module is working.

AFTER-SALES MAINTENANCE



HYDRA[®]
— **INSTALL** —

MAINTENANCE (CONTINUED)

SEMI-ANNUALLY

Check ground bolt torque and tighten if required.

ANNUALLY

Check all internal components.

ON-SITE MAINTENANCE

This device is an internet of Things-type charger with pre-charge self-test, daily regular self-test, online monitoring of electrical parts and other intelligent functions.

- If working, simply perform routine maintenance, no overhaul maintenance is required.
- If not working properly, promptly contact the customer service centre or local supplier.

REMOTE MAINTENANCE

The charger has the function of connecting to the device cloud platform to monitor the status of the charger in real time. When connected, the platform can provide perfect remote diagnosis, remote service and remote upgrade services. It can also locate problems and provide solutions to help the operation centre carry out remote services. It can remotely upgrade software, solve end-user problems and carry out unattended operations.

- The system self-tests daily. If there is an issue, it will escalate it automatically.
- If there is an abnormal operation, please contact the customer service centre or local supplier promptly.
- Service engineers can query logs, update configuration and procedures, carry out remote management, diagnosis, configuration, upgrades and other remote maintenance actions.

HYDRA